



Elevation A



Clean + Modern
Build Design



Upscale Stone & Stucco
Exterior Available



9' Main Floor
Ceiling Height



Full Suite of
Interior Finishes



Elevation B

- * 3 Bedrooms
- * 2.5 Bathrooms
- * Basement Rough-in

- * Single Garage
- * Luxury Vinyl
- * Covered Porch

- * Two Elevations
- * Master Bed Ensuite
- * Kitchen Island

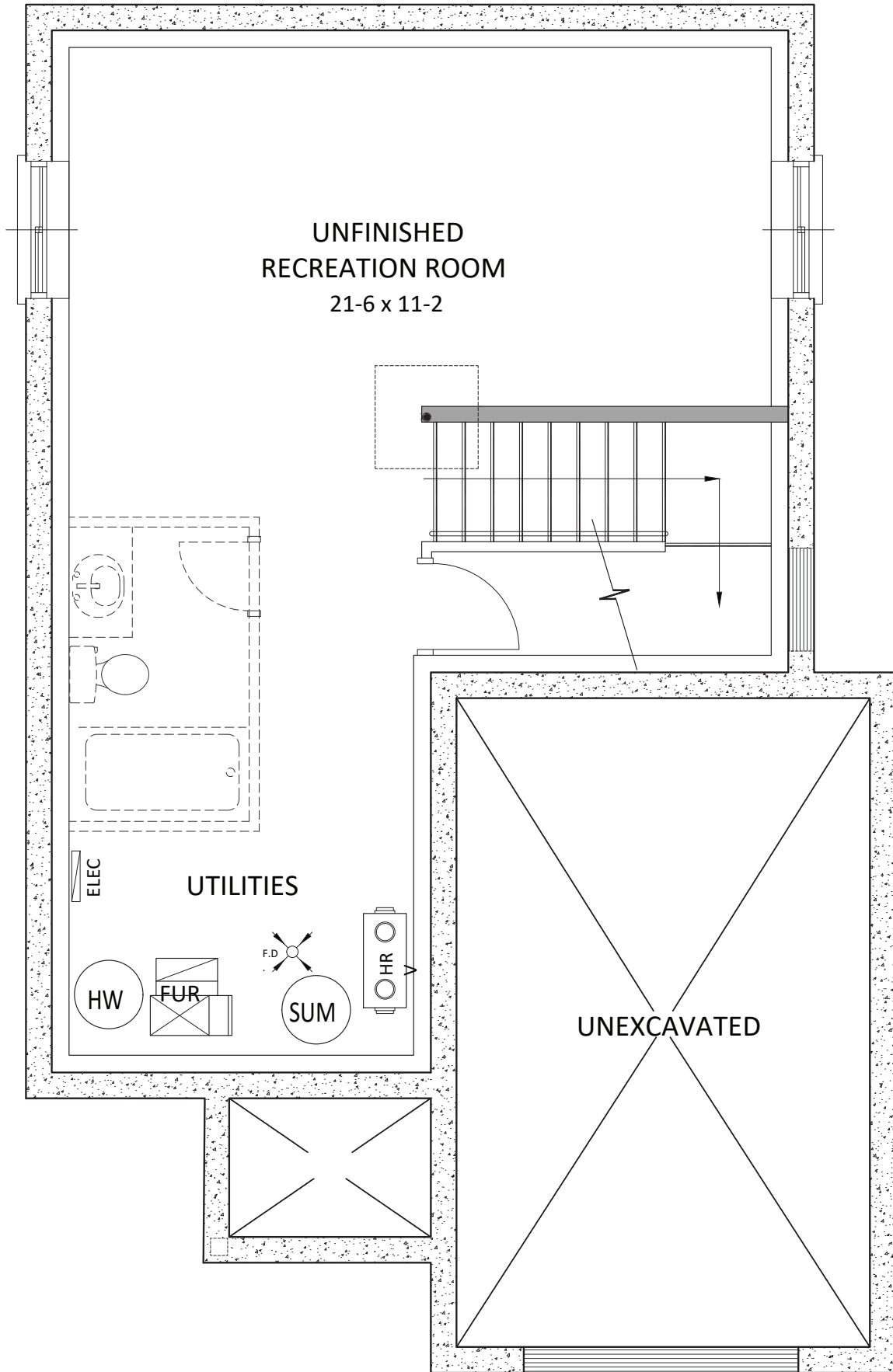

BASEMENT

ELEVATION B

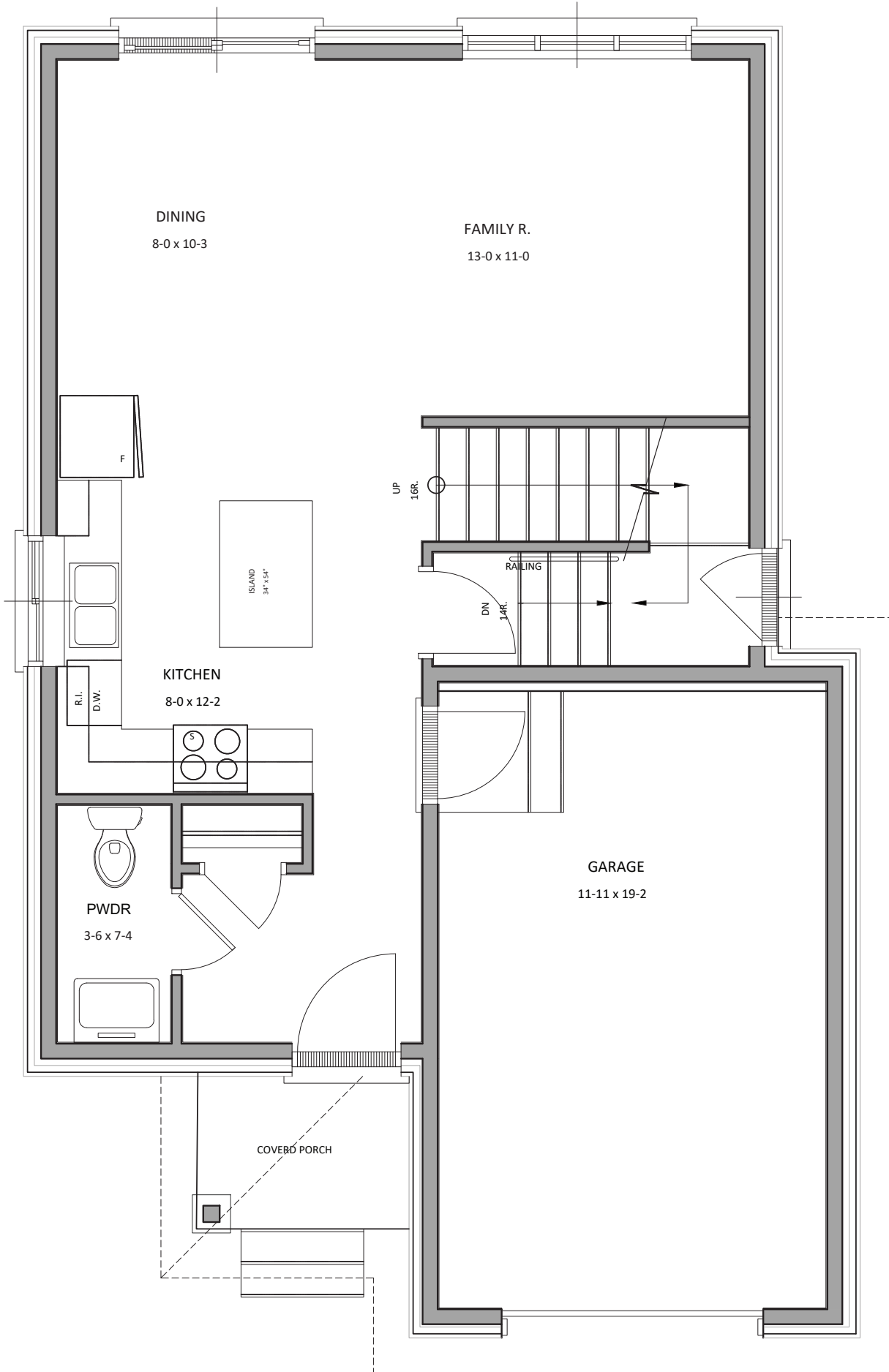

MAIN FLOOR

ELEVATION B

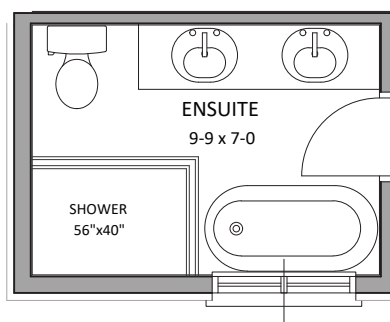
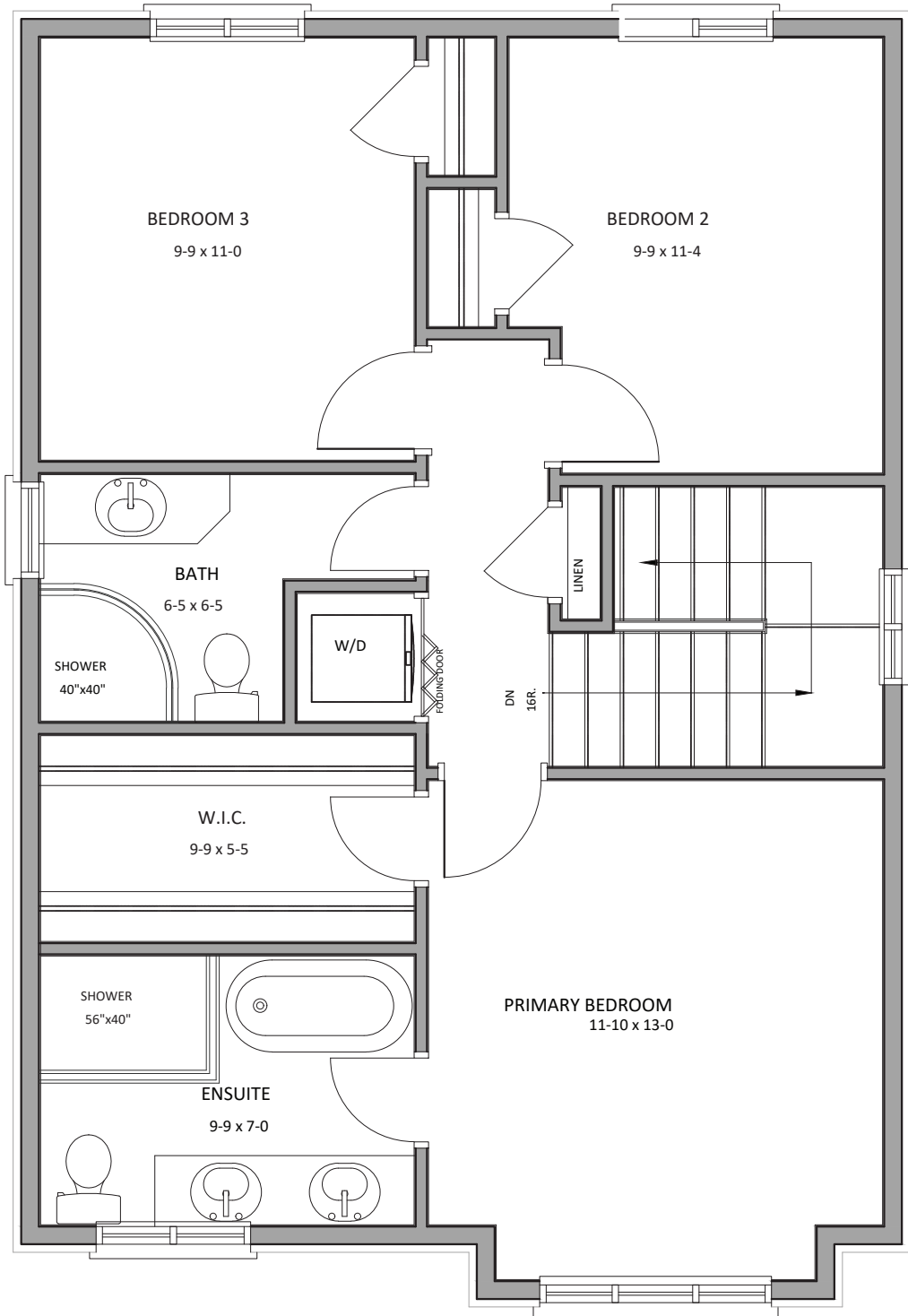

Optional Layout
ELEVATION B

SECOND FLOOR

ELEVATION B